

## Customers trust in THELEN.

### Six further orders, for optical sorters.

Thelen-machines is the point of contact for food processing customers. The focus is on potatoes, vegetables, and salads, but also other products.

At the end of the year, another three customers in Germany were convinced and decided for our belt sorting machines.

- Four machines for quality sorting of **sliced potatoes**
- One machine for the quality sorting of **salads-herbs**.
- One machine for sorting of whole, **peeled potatoes**.

Five TOMRA-machines in a sorting conveyor belt width of 2000 mm as well as a freefall Sorter!

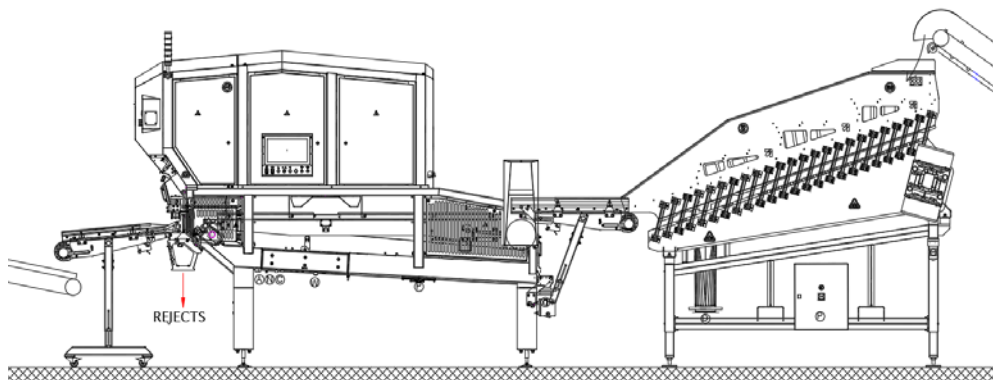

#### Advantages:

- ✓ Detects the smallest defects
- ✓ Detection of the finest colour deviation
- ✓ Transport belt damages and shadows are electronically hidden and negated
- ✓ 4K Colour Cameras
- ✓ Intuitive User Interface: Easy Graphical Setup & Operation

#### Advantages of the Clean-Design:

- ✓ All surfaces are inclined – dirt is always washed away – no water remains, which leads to limescale deposits, etc.
- ✓ No cable ducts where product is left behind. Almost all cables are installed in the frame but are accessible via inspection and maintenance openings.
- ✓ Additional intervention protection, i.e. additional safety component to prevent foreign objects from entering the machine and further improved accident protection. Easy to open – (machine stops).
- ✓ Control cabinets and all doors are also inclined and sealed with endless seal, so that a gap can no longer be created by shrinking seal.
- ✓ Control cabinets and all doors with sealing right at the edge, so it is no longer possible for product or dirt to be flushed under the door edges during cleaning.